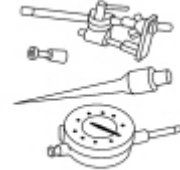
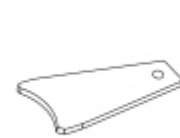

Ring Gear Backlash Adjustment

Special Tool(s)

 <p>ST1214-A</p>	<p>Dial Indicator Gauge With Holding Fixture 100-002 (TOOL-4201-C)</p>
 <p>ST1485-A</p>	<p>Installer, Differential Shim 205-220 (T85L-4067-AH)</p>

Material

Item	Specification
<p>Motorcraft® High Contrast Hypoid Gear Marking Compound XG-14</p>	<p>—</p>

1. Remove the differential housing cover. For additional information, refer to [Differential Housing Cover](#) in this section.
2. Install the Dial Indicator Gauge with Holding Fixture and measure the ring gear backlash.
 - If a zero backlash condition occurs or the backlash is not within specification, proceed to Step 3.
 - If the backlash is within specification, proceed to Step 14.

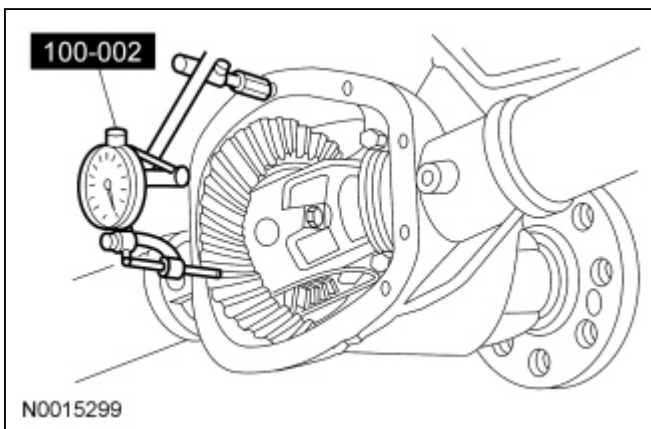

3. Remove the axle shafts. For additional information, refer to [Axle Shaft](#) in this section.
4. **NOTE:** Index-mark the position of the differential bearing caps, as arrows may not be visible. The differential bearing caps must be installed in their original locations and positions.

Remove the 4 differential bearing cap bolts and 2 caps.

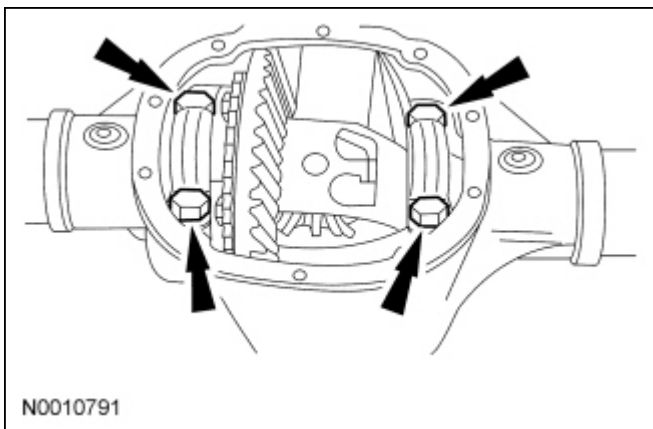

5. If a zero backlash condition had occurred, add 0.50 mm (0.020 in) to the RH side shim and subtract 0.50 mm (0.020 in) from the LH side shim to allow a backlash indication. Install the 2 bearing caps and 4 bolts.
 - Tighten to 105 Nm (77 lb-ft).
 - Go back to Step 2.

6. To correct for high or low backlash, increase the thickness of one differential bearing shim and decrease the thickness of the other differential bearing shim by the same amount. Refer to the following tables when adjusting the backlash.

Backlash Change Required		Thickness Change Required	
mm	Inch	mm	Inch
0.025	0.001	0.050	0.002
0.050	0.002	0.050	0.002
0.076	0.003	0.101	0.004
0.101	0.004	0.152	0.006
0.127	0.005	0.152	0.006
0.152	0.006	0.203	0.008
0.177	0.007	0.254	0.010
0.203	0.008	0.254	0.010
0.228	0.009	0.304	0.012
0.254	0.010	0.355	0.014
0.279	0.011	0.355	0.014
0.304	0.012	0.406	0.016
0.330	0.013	0.457	0.018
0.335	0.014	0.457	0.018
0.381	0.015	0.508	0.020

Differential Shim Size Chart 4067

Stripes and Color Code	Dimension A	
	mm	Inch
2 — C-COAL	7.7978-7.8105	0.3070-0.3075
1 — C-COAL	7.7470-7.7597	0.3050-0.3055

5 — BLU	7.6962-7.7089	0.3030-0.3035
4 — BLU	7.6454-7.6581	0.3010-0.3015
3 — BLU	7.5946-7.6073	0.2990-0.2995
2 — BLU	7.5458-7.5565	0.2970-0.2975
5 — PINK	7.4422-7.4549	0.2930-0.2935
4 — PINK	7.3914-7.4041	0.2910-0.2915
3 — PINK	7.3406-7.3533	0.2890-0.2895
2 — PINK	7.2898-7.3025	0.2870-0.2875
1 — PINK	7.2390-7.2517	0.2850-0.2855
5 — GRN	7.1882-7.2009	0.2830-0.2835
4 — GRN	7.1374-7.1501	0.2810-0.2815
3 — GRN	7.0866-7.0993	0.2790-0.2795
2 — GRN	7.0358-7.0485	0.2770-0.2775
1 — GRN	6.9850-7.0485	0.2750-0.2755
5 — WH	6.9342-6.9469	0.2730-0.2735
4 — WH	6.8834-6.8961	0.2710-0.2715
3 — WH	6.8326-6.8453	0.2690-0.2695
2 — WH	6.7818-6.7945	0.2670-0.2675
1 — WH	6.7310-6.7437	0.2650-0.2655
5 — YEL	6.6802-6.6929	0.2630-0.2635
4 — YEL	6.6294-6.6421	0.2610-0.2615
3 — YEL	6.5786-6.5913	0.2590-0.2595
2 — YEL	6.5278-6.5405	0.2570-0.2575
1 — YEL	6.4770-6.4897	0.2550-0.2555
5 — ORNG	6.4262-6.4389	0.2530-0.2535
4 — ORNG	6.3754-6.3881	0.2510-0.2515
3 — ORNG	6.3246-6.3373	0.2490-0.2495
2 — ORNG	6.2738-6.2865	0.2470-0.2475
1 — ORNG	6.2223-6.2357	0.2450-0.2455
2 — RED	6.1722-6.1849	0.2430-0.2435
1 — RED	6.1214-6.1341	0.2410-0.2415

7. Install the 2 differential bearing caps and 4 bolts.
 - Tighten to 105 Nm (77 lb-ft).

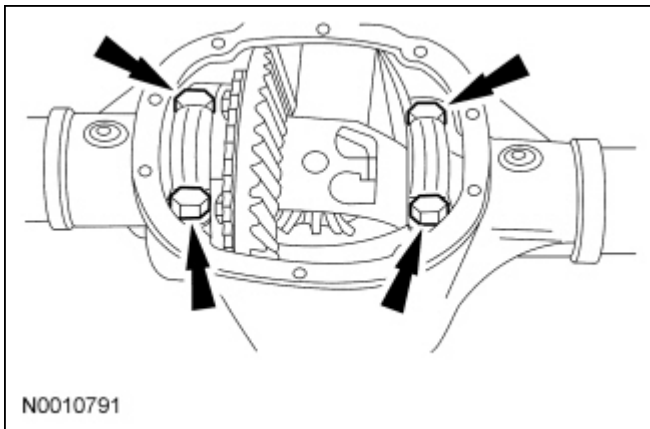

8. Using the Dial Indicator Gauge with Holding Fixture, recheck the ring gear backlash.
 - If backlash is now within specification, proceed to Step 9.
 - If backlash is not within specification, go back to Step 4.

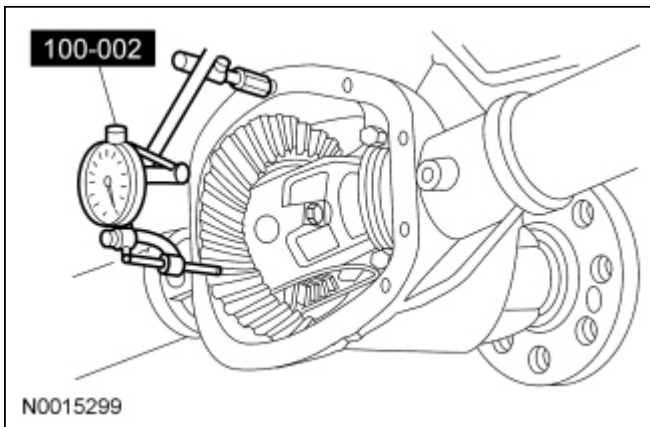

9. Remove the 4 bearing cap bolts and 2 bearing caps.
10. To establish differential bearing preload, increase both LH and RH differential bearing shim size by the thickness shown.

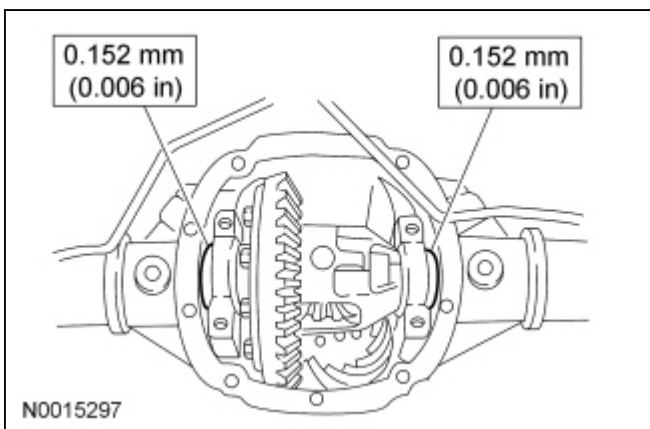

11. Using the Differential Shim Installer, fully seat the differential bearing shims. Make sure the assembly rotates freely.

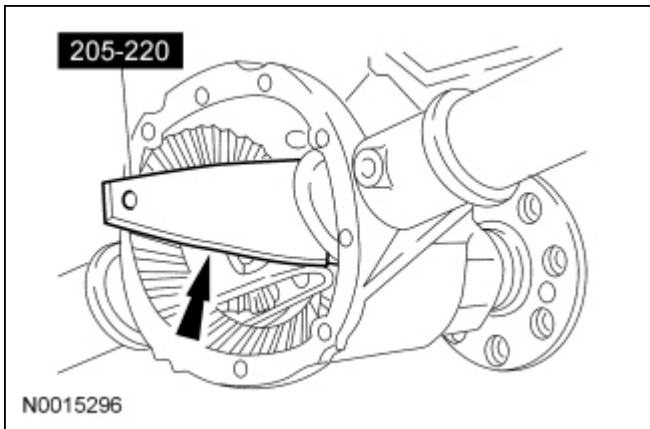

12. Install the 2 differential bearing caps and 4 bolts.
 - Tighten to 105 Nm (77 lb-ft).

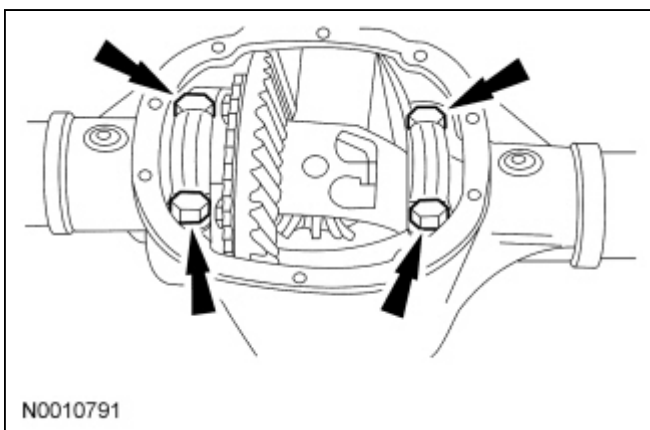

13. Using the Dial Indicator Gauge with Holding Fixture, do a final check of the ring gear backlash.

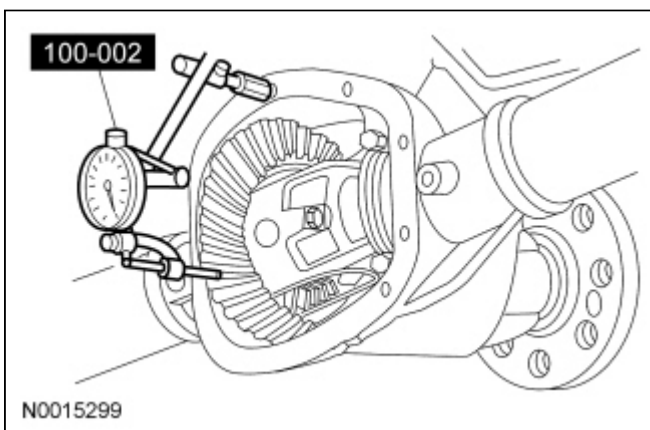

14. Apply marking compound and rotate the differential assembly 5 complete revolutions.
15. Verify an acceptable pattern check. For additional information, refer to Tooth Contact Pattern Check in [Section 205-00](#).
16. Install the axle shafts. For additional information, refer to [Axle Shaft](#) in this section.
17. Install the differential housing cover. For additional information, refer to [Differential Housing Cover](#) in this section.

